



BOXSM
TECHNOLOGY

Network Connectivity Guide for BOX Options

Document Revision: 4.6
Date of Issue : July 24 2024

Document History

Version	Date	Change Description
4.0	2021-12-22	New version of the connectivity guide
4.1	2022-03-14	Updated multicast line tables to correct errors
4.2, 4.2.1	2022-04-12	Updated market data bandwidth requirements
4.3	2023-03-21	Updated market data section to remove references to 1Gigabit Top of Book feed, add new multicast lines for the additional trading slices, remove references to ISV1 test environment, and updated market data bandwidth requirements.
4.4	2023-10-24	Updated section A.5 for new switch connection limit
4.5	2024-03-14	Updated section A.5 for new switch connection limit
4.6	2024-07-24	Updated market data bandwidth requirements in Appendix B

Table of Contents

Table of Contents	i
Section 1 Introduction.....	2
1.1 Audience	2
1.2 Related Documents	2
1.3 BOX Contact	2
Section 2 BOX Extranet	3
2.1 NY4 Production	3
2.2 NY4 Test	3
2.3 CH1 Disaster Recovery (“DR”)	3
Section 3 Connectivity	4
3.1 Equalized Cross Connect	4
3.2 Equinix Cross Connect	4
3.3 Extranet Providers	4
3.4 VPN.....	5
3.5 Connectivity Request.....	5
Section 4 Network Specifications	6
4.1 IP Addresses.....	6
4.2 Peering IP Addresses	6
4.3 IP Routing	6
4.4 Multicast.....	6
4.5 Network Security	7
Section 5 HSVF Market Data.....	8
5.1 High Speed Vendor Feed (“HSVF”) Multicast	8
5.2 Redundancy	9
5.3 Clear Leader	9
5.4 Message Recovery (Retransmission).....	9

Section 1 Introduction

The Network Connectivity Guide explains the network connectivity options to access BOX Options Market LLC (“BOX”) trading systems and services.

1.1 Audience

This document targets business, programmers, and network analysts who are responsible for determining the technical solutions needed to interface with BOX’s trading systems and services.

1.2 Related Documents

Please refer to BOX’s website (www.boxoptions.com) to access protocol specifications and business design guides.

1.3 BOX Contact

Market Operations Center

- Toll Free: 1-866-768- 8845
- boxmoc@boxoptions.com

Section 2 **BOX Extranet**

Connectivity to BOX services is provided via the BOX Extranet. Connections to BOX via the Extranet will be either directly via a cross connect or indirectly via a third-party network provider (“Extranet Provider”).

2.1 NY4 Production

The Production Extranet is hosted within the Equinix NY4 data center. Access to the Production Extranet is provided via an equalized cabling architecture. All production connections (including Extranet Providers) must use the equalized cabling architecture.

2.2 NY4 Test

Test environments are hosted in the NY4 data center and are accessible via a separate Test Extranet or via VPN.

The Test Extranet utilizes the same switch models and similar architecture as the Production Extranet.

Participants and Extranet Providers (collectively, “firms”) may also opt to access the test environment via their production connection. However, this is not recommended by BOX as firms may impact their production traffic performance if they access the test environment at the same time.

2.3 CH1 Disaster Recovery (“DR”)

The BOX DR systems are hosted in the Equinix CH1 data center. Firms must connect to this location to access the BOX DR environment. Connections in CH1 use standard Equinix cross connects to obtain access to the BOX DR Extranet.

This location provides access to the BOX DR systems only.

Section 3 Connectivity

The BOX Extranet supports 1G and 10G connections. Alternatively, firms may opt to connect using an Extranet Provider.

Depending on the environment accessed, different connection types are available:

<u>Environment</u>	<u>Location</u>	<u>Equalized Connection</u>	<u>Equinix Cross Connect</u>	<u>Third Party</u>	<u>VPN</u>
Production	NY4	Yes	No	Yes	No
Test	NY4	No	Yes	Yes	Yes
DR	CH1	No	Yes	Yes	No

3.1 Equalized Cross Connect

In the NY4 data center, BOX has implemented equalized cross connects. All firm connections to the production environment, originating from within the NY4 data center, must use equalized cross connects.

All equal distance cross connects are provided on single mode fiber and support 1000BASE-LX/LH or 10GBASE-LR signalling.

3.2 Equinix Cross Connect

Firms that would like a direct connection to the test and DR environments can do so using Equinix cross connects.

BOX supports single mode fiber and either 1000BASE-LX/LH or 10GBASE-LR signalling.

3.3 Extranet Providers

Several Extranet Providers offer connectivity to the BOX environments. Please refer to the BOX website for a list of current Extranet Providers. Firms should contact the Extranet Providers for connectivity.

3.4 VPN

VPN access is available for the test environment only. Note that VPN connections cannot provide access to the test market data as the multicast feed is not supported over VPN. The following VPN settings are supported:

<u>Parameters</u>	<u>Accepted Values</u>
Internet Key Exchange Encryption (IKE) Method	Advanced Encryption Standard (AES) [256 bits] or AES256CGM
Data Integrity Method (Supported methods: SHA, MD5)	SHA [512] [PRFSHA512]
Authentication Method	Pre-shared Private Key
Private Key	BOX will provide the Private key over the phone during implementation.
Diffie-Hellman (DH) group	Group 14, 20 or 21 and above (minimum 2048 bit)
IKE SA lifetime	86400 seconds (1 day)
IPSec SA lifetime	3600 seconds (1 hour)
Data Exchange Encryption Algorithm	Advanced Encryption Standard (AES) [192 / 256 bits]
Data Integrity	SHA [256 / 384 / 512]
PFS (Perfect Forward Secrecy)	YES

3.5 Connectivity Request

Firms that wish to order, upgrade, downgrade, or cancel a connection to BOX must first reach out the Market Operations Center and complete a Connectivity Request Form. This form will ask the firm to provide the necessary information needed to provision, modify, or cancel the requested connection(s).

Section 4 Network Specifications

4.1 IP Addresses

The firm must provide the IP addresses of its hosts that will connect to the BOX applications. BOX requests public IP addresses assigned by the IANA. If public IP addresses are not available, the firm may choose to use private (non-routable) addresses from the reserved IP address ranges as outlined in RFC1597, provided that the addresses do not conflict with any addresses currently used on the BOX networks.

4.2 Peering IP Addresses

The network device peer addresses assigned to the Ethernet links that connect firm equipment to the BOX trading network will be assigned by BOX unless firms supply their own addresses.

4.3 IP Routing

Either static routes or Border Gateway Protocol (“BGP”) are supported and will distribute routing information between BOX and firms.

4.4 Multicast

The BOX multicast network uses PIM sparse mode (“PIM-SM”) exclusively. PIM dense mode (“PIM-DM”) or static Internet Group Management Protocol (“IGMP”) joins are not supported.

PIM-SM requires the use of a Rendezvous Point (“RP”) towards which firm routers forward multicast join requests.

Each feed is sourced from an address range specific to its source location. For optimal multicast routing, firms are expected to support the creation of shortest path trees (“SPT”). This will ensure the lowest latency, most efficient reception of the feeds, and will allow firms to control the redundant reception of both A and B feeds.

Optimal feed reception ultimately depends on the source tree determined from the firm’s router point of view. The location from which firms receive a feed will depend on the routes to the source address range contained within the firm router’s unicast routing table. Firms’ unicast routing tables must be accurate to ensure they receive the feeds from their intended location.

To aid firms in obtaining the multicast feeds from the desired locations, appropriate routes will be advertised via BGP. Firms must configure their network equipment to accept the desired routes from their preferred locations and thus determine the unicast routing table that will be used to create the source tree back to the feed sources. Please refer to the appendix for detailed information.

4.5 Network Security

BOX implements various security measures to protect its systems from malicious activity. The security measures in place are meant to protect the BOX networks and systems and are in no way intended to provide security to firms themselves. If firms feel they require additional security for their networks, they are encouraged to put in place the security measures deemed appropriate.

BOX reserves the right to capture and store network traffic for monitoring, analysis, and troubleshooting purposes.

BOX reserves the right to administratively and/or physically disable any connection which is believed to pose a security risk to the BOX systems.

Section 5 HSVF Market Data

5.1 High Speed Vendor Feed (“HSVF”) Multicast

BOX market data is disseminated via multicast. For each trading slice, the HSVF is offered in different instances so that firms may choose the market data messages they wish to receive.

<u>Description</u>	<u>Line Designation</u>	<u>HSVF Messages Included</u>
Top of Book (Level 1)	s1 (s specifies the trading slice)	Options: C, D, F, GC, GR, I, J, M, N, O, Q, T Complex Order (Strategy): CS, FS, GS IS, JS, MS, NS, OS, QS, TS
Market Depth (Level 5)	s5 (s specifies the trading slice)	Options: C, D, GC, GR, H, I, J, M, N, O, Q, T Complex Order (Strategy): CS, GS, HS, IS, JS, MS, NS, OS, QS, TS
PIP only	sP (s specifies the trading slice)	Options: J, M, N, O, Q, T Complex Order (Strategy): JS, MS, NS, OS, QS, TS
Complex Order (with market depth)	sC (s specifies the trading slice)	Complex Order (Strategy): CS, GS, HS, IS, JS, MS, NS, OS, QS, TS

5.2 Redundancy

The HSVF is disseminated redundantly via “A” and “B” versions of the feed.

5.3 Clear Leader

The HSVF components have been deployed so that the “A” feed is generated before the “B” feed. For each feed, Top of Book is generated first.

5.4 Message Recovery (Retransmission)

A feed retransmission service is provided so that firms may request messages they may have missed on the HSVF. This service is offered over TCP to dedicated retransmission servers.

For redundancy, two recovery servers are available. Either server can be used to retrieve missing messages as the recovery systems are not tied to a specific version of the feed. Since both the A and B feeds are identical, firms can connect to any recovery server to retrieve missing messages.

If a recovery server is not available (due to a technical issue), firms must connect to the alternate server to request message retransmission.

Appendix A NY4 Equalized Cabling Details

A.1 Architecture

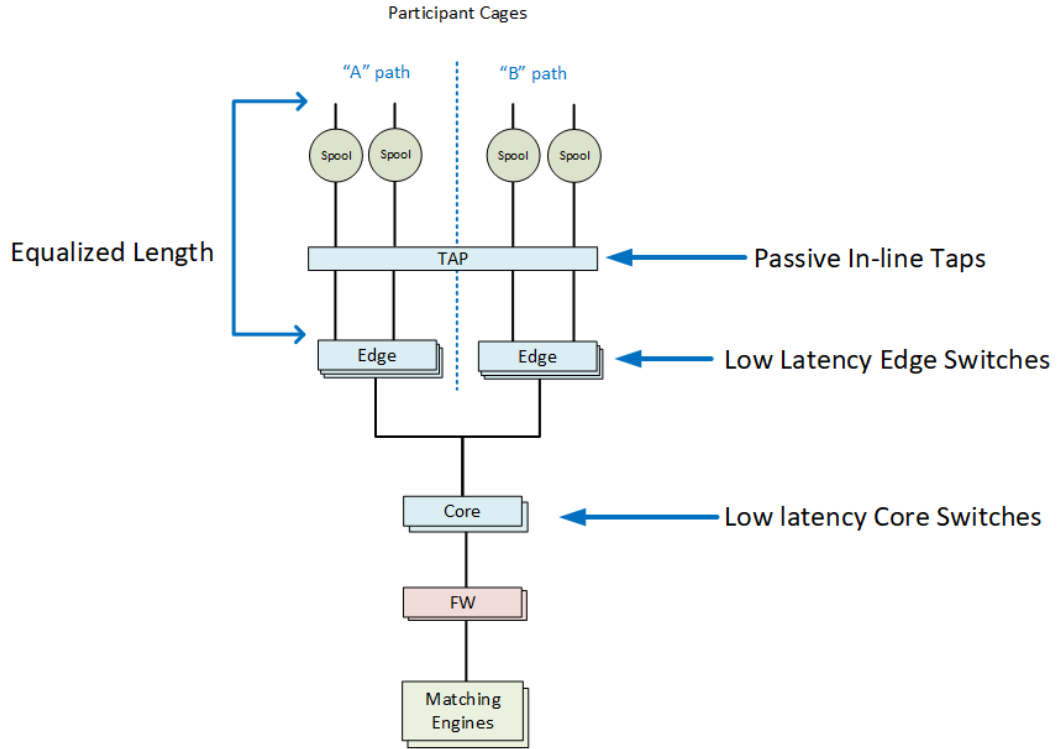

A.2 Optical Fiber Specifications

Location	Connection Speed	Fiber Type	Signal	Connector
NY4	1G	Single Mode	1000BASE-LX/LH	LC
	10G	Single Mode	10GBASE-LR	LC

Equalized fiber spools are equalized to +/-1 optical foot.

A.3 Path Redundancy

To provide firms with redundant paths, "A" path and "B" paths, fiber spools are available. All fiber spools are of equalized length. The "A" fiber follows one path to the BOX cage whereas the "B" fiber follows an alternate path.

"A" path fiber will terminate on "A" edge switches and "B" path fiber will terminate on "B" edge switches.

For redundancy, it is strongly recommended that firms obtain at least one "A" path and one "B" path connection.

A.4 Edge Switches

The BOX Extranet edge switches are dedicated to a specific fiber path and connection speed. Edge switches will not mix connection speeds or fiber paths.

<u>Fiber Path</u>	<u>Number of Switches for 10G Connections</u>	<u>Number of Switches for 1G Connections</u>
A	3	1
B	3	1

Each edge switch is equipped with three distinct memory blocks, each responsible for a subset of a switch's interfaces. Interfaces on memory blocks 2 and 3 will be used for firm connections.

A.5 Limitations on Connections

Firms can order a maximum of six (6) connections per individual switch, three (3) maximum per memory block.

A.6 Ordering Connections

Firms that wish to connect to BOX must first reach out to the Market Operations Center and complete a Connectivity Request Form. This form will ask the firm to provide the necessary information needed to provision the requested connection(s).

When firms order a connection, they must indicate whether they wish to use the "A" or "B" path for each cross connect. Firms may also choose which edge switch they wish to connect to.

The BOX network team will assign switch ports in a randomized and anonymized fashion, ensuring that a firm does not exceed the connection limitations indicated above.

A.7 Certification

All fiber spools have been pre-certified to BOX's optical length specifications. In addition, BOX reserves the right to recertify any or all fiber spools to ensure the fibers have not been modified.

Appendix B Market Data Bandwidth Requirements

The following bandwidth requirements are provided to ensure connections are sized appropriately to receive market data. The following table shows the required bandwidth needed to receive a single instance of a HSVF service. Firms must not over-subscribe to market data (i.e. subscribe to multiple services of the feed on a connection where the total bandwidth would exceed the capacity of the connection).

<u>Service</u>	<u>"A" Feed Bandwidth</u>	<u>"B" Feed Bandwidth</u>
Top of Book HSVF	5Gbps	1Gbps
Market Depth HSVF	2Gbps	1Gbps
PIP HSVF	1Gbps	1Gbps
Complex Order HSVF	1Gbps	1Gbps

Appendix C Production (NY4) HSVF Details

C.1 Rendezvous Point (“RP”)

<u>Description</u>	<u>Address</u>
NY4 production RP	198.235.27.223

C.2 HSVF Multicast Sources

<u>Description</u>	<u>Source IPs</u>	<u>Advertised Routes</u>
NY4 production “A” feed	198.235.27.40	198.235.27.40/32
	198.235.27.41	198.235.27.41/32
	Subnet	198.235.27.40/29
NY4 production “B” feed	198.235.27.48	198.235.27.48/32
	198.235.27.49	198.235.27.49/32
	Subnet	198.235.27.48/29

C.3 HSVF Multicast Lines

<u>NY4 Production</u>					
<u>Line</u>	<u>Description</u>	<u>“A” Feed Multicast Group Addresses</u>	<u>UDP Port</u>	<u>“B” Feed Multicast Group Addresses</u>	<u>UDP Port</u>
11	Top of book	224.0.124.1	21401	224.0.124.49	21404
21	Top of book	224.0.124.2	22401	224.0.124.50	22404
31	Top of book	224.0.124.3	23401	224.0.124.51	23404
41	Top of book	224.0.124.4	24401	224.0.124.52	24404
51	Top of book	224.0.124.5	25401	224.0.124.53	25404
61	Top of book	224.0.124.6	26401	224.0.124.54	26404
71	Top of book	224.0.124.7	27401	224.0.124.55	27404
81	Top of book	224.0.124.8	28401	224.0.124.56	28404

NY4 Production					
Line	Description	“A” Feed Multicast Group Addresses	UDP Port	“B” Feed Multicast Group Addresses	UDP Port
91	Top of book	224.0.124.33	29401	224.0.124.37	29404
A1	Top of book	224.0.124.34	30401	224.0.124.38	30404
B1	Top of book	224.0.124.35	31401	224.0.124.39	31404
C1	Top of book	224.0.124.36	32401	224.0.124.40	32404
15	Market Depth	224.0.124.9	21402	224.0.124.57	21405
25	Market Depth	224.0.124.10	22402	224.0.124.58	22405
35	Market Depth	224.0.124.11	23402	224.0.124.59	23405
45	Market Depth	224.0.124.12	24402	224.0.124.60	24405
55	Market Depth	224.0.124.13	25402	224.0.124.61	25405
65	Market Depth	224.0.124.14	26402	224.0.124.62	26405
75	Market Depth	224.0.124.15	27402	224.0.124.63	27405
85	Market Depth	224.0.124.16	28402	224.0.124.64	28405
95	Market Depth	224.0.124.81	29402	224.0.124.85	29405
A5	Market Depth	224.0.124.82	30402	224.0.124.86	30405
B5	Market Depth	224.0.124.83	31402	224.0.124.87	31405
C5	Market Depth	224.0.124.84	32402	224.0.124.88	32405
1P	PIP only	224.0.124.17	21403	224.0.124.65	21406
2P	PIP only	224.0.124.18	22403	224.0.124.66	22406
3P	PIP only	224.0.124.19	23403	224.0.124.67	23406
4P	PIP only	224.0.124.20	24403	224.0.124.68	24406
5P	PIP only	224.0.124.21	25403	224.0.124.69	25406
6P	PIP only	224.0.124.22	26403	224.0.124.70	26406
7P	PIP only	224.0.124.23	27403	224.0.124.71	27406
8P	PIP only	224.0.124.24	28403	224.0.124.72	28406

NY4 Production					
<u>Line</u>	<u>Description</u>	<u>“A” Feed Multicast Group Addresses</u>	<u>UDP Port</u>	<u>“B” Feed Multicast Group Addresses</u>	<u>UDP Port</u>
9P	PIP only	224.0.124.89	29403	224.0.124.93	29406
AP	PIP only	224.0.124.90	30403	224.0.124.94	30406
BP	PIP only	224.0.124.91	31403	224.0.124.95	31406
CP	PIP only	224.0.124.92	32403	224.0.124.96	32406
1C	Complex Order	224.0.124.25	21407	224.0.124.73	21408
2C	Complex Order	224.0.124.26	22407	224.0.124.74	22408
3C	Complex Order	224.0.124.27	23407	224.0.124.75	23408
4C	Complex Order	224.0.124.28	24407	224.0.124.76	24408
5C	Complex Order	224.0.124.29	25407	224.0.124.77	25408
6C	Complex Order	224.0.124.30	26407	224.0.124.78	26408
7C	Complex Order	224.0.124.31	27407	224.0.124.79	27408
8C	Complex Order	224.0.124.32	28407	224.0.124.80	28408
9C	Complex Order	224.0.124.129	29407	224.0.124.133	29408
AC	Complex Order	224.0.124.130	30407	224.0.124.134	30408
BC	Complex Order	224.0.124.131	31407	224.0.124.135	31408
CC	Complex Order	224.0.124.132	32407	224.0.124.136	32408

C.4 IP Source to HSVF Multicast Line Mapping

NY4 Production					
<u>Top of Book Lines</u>	<u>Market Depth Lines</u>	<u>PIP Lines</u>	<u>Complex Order Lines</u>	<u>“A” Feed Sources</u>	<u>“B” Feed Sources</u>
11	15	1P	1C	198.235.27.41	198.235.27.49
21	25	2P	2C	198.235.27.41	198.235.27.49
31	35	3P	3C	198.235.27.41	198.235.27.49

41	45	4P	4C	198.235.27.40	198.235.27.48
51	55	5P	5C	198.235.27.40	198.235.27.48
61	65	6P	6C	198.235.27.40	198.235.27.48
71	75	7P	7C	198.235.27.40	198.235.27.48
81	85	8P	8C	198.235.27.40	198.235.27.48
91	95	9P	9C	198.235.27.40	198.235.27.48
A1	A5	AP	AC	198.235.27.41	198.235.27.49
B1	B5	BP	BC	198.235.27.41	198.235.27.49
C1	C5	CP	CC	198.235.27.41	198.235.27.49

C.5 Retransmission

<u>Feeds</u>	<u>NY4 Retransmission Server 1</u>	<u>NY4 Retransmission Server 2</u>	<u>TCP Port</u>
Trading slice 1 (11, 15, 1P, 1C)	198.235.27.47	198.235.27.55	21410
Trading slice 2 (21, 25, 2P, 2C)	198.235.27.47	198.235.27.55	22410
Trading slice 3 (31, 35, 3P, 3C)	198.235.27.47	198.235.27.55	23410
Trading slice 4 (41, 45, 4P, 4C)	198.235.27.47	198.235.27.55	24410
Trading slice 5 (51, 55, 5P, 5C)	198.235.27.47	198.235.27.55	25410
Trading slice 6 (61, 65, 6P, 6C)	198.235.27.47	198.235.27.55	26410
Trading slice 7 (71, 75, 7P, 7C)	198.235.27.47	198.235.27.55	27410
Trading slice 8 (81, 85, 8P, 8C)	198.235.27.47	198.235.27.55	28410
Trading slice 9 (91, 95, 9P, 9C)	198.235.27.47	198.235.27.55	29410
Trading slice 10 (A1, A5, AP, AC)	198.235.27.47	198.235.27.55	30410
Trading slice 11	198.235.27.47	198.235.27.55	31410

<u>Feeds</u>	<u>NY4 Retransmission Server</u> <u>1</u>	<u>NY4 Retransmission Server</u> <u>2</u>	<u>TCP Port</u>
(B1, B5, BP, BC)			
Trading slice 12 (C1, C5, CP, CC)	198.235.27.47	198.235.27.55	32410

Appendix D Disaster Recovery (CH1) HSVF Details

The DR HSVF is available when BOX's DR systems are activated.

D.1 DR Rendezvous Point ("RP")

Description	Address
CH1 DR RP	198.235.27.222

D.2 DR HSVF Multicast Sources

Description	Source IPs	Advertised Routes
CH1 DR "A" feed	198.235.27.232	198.235.27.232/29
	198.235.27.233	
	Subnet	
CH1 DR "B" feed	198.235.27.240	198.235.27.240/29
	198.235.27.241	
	Subnet	

D.3 DR HSVF Multicast Lines

CH1 DR					
Line	Description	"A" Feed Multicast Group Addresses	UDP Port	"B" Feed Multicast Group Addresses	UDP Port
11	Top of book	224.0.124.97	21401	224.0.124.145	21404
21	Top of book	224.0.124.98	22401	224.0.124.146	22404
31	Top of book	224.0.124.99	23401	224.0.124.147	23404
41	Top of book	224.0.124.100	24401	224.0.124.148	24404
51	Top of book	224.0.124.101	25401	224.0.124.149	25404
61	Top of book	224.0.124.102	26401	224.0.124.150	26404
71	Top of book	224.0.124.103	27401	224.0.124.151	27404

CH1 DR					
<u>Line</u>	<u>Description</u>	<u>“A” Feed Multicast Group Addresses</u>	<u>UDP Port</u>	<u>“B” Feed Multicast Group Addresses</u>	<u>UDP Port</u>
81	Top of book	224.0.124.104	28401	224.0.124.152	28404
91	Top of book	224.0.124.137	29401	224.0.124.141	24404
A1	Top of book	224.0.124.138	30401	224.0.124.142	25404
B1	Top of book	224.0.124.139	31401	224.0.124.143	26404
C1	Top of book	224.0.124.140	32401	224.0.124.144	27404
15	Market depth	224.0.124.105	21402	224.0.124.153	21405
25	Market depth	224.0.124.106	22402	224.0.124.154	22405
35	Market depth	224.0.124.107	23402	224.0.124.155	23405
45	Market depth	224.0.124.108	24402	224.0.124.156	24405
55	Market depth	224.0.124.109	25402	224.0.124.157	25405
65	Market depth	224.0.124.110	26402	224.0.124.158	26405
75	Market depth	224.0.124.111	27402	224.0.124.159	27405
85	Market depth	224.0.124.112	28402	224.0.124.160	28405
95	Market depth	224.0.124.177	29402	224.0.124.181	29405
A5	Market depth	224.0.124.178	30402	224.0.124.182	30405
B5	Market depth	224.0.124.179	31402	224.0.124.183	31405
C5	Market depth	224.0.124.180	32402	224.0.124.184	32405
1P	PIP only	224.0.124.113	21403	224.0.124.161	21406
2P	PIP only	224.0.124.114	22403	224.0.124.162	22406
3P	PIP only	224.0.124.115	23403	224.0.124.163	23406
4P	PIP only	224.0.124.116	24403	224.0.124.164	24406
5P	PIP only	224.0.124.117	25403	224.0.124.165	25406
6P	PIP only	224.0.124.118	26403	224.0.124.166	26406
7P	PIP only	224.0.124.119	27403	224.0.124.167	27406
8P	PIP only	224.0.124.120	28403	224.0.124.168	28406

CH1 DR					
<u>Line</u>	<u>Description</u>	<u>“A” Feed Multicast Group Addresses</u>	<u>UDP Port</u>	<u>“B” Feed Multicast Group Addresses</u>	<u>UDP Port</u>
9P	PIP only	224.0.124.224	29403	224.0.124.228	29406
AP	PIP only	224.0.124.225	30403	224.0.124.229	30406
BP	PIP only	224.0.124.226	31403	224.0.124.230	31406
CP	PIP only	224.0.124.227	32403	224.0.124.231	32406
1C	Complex Order	224.0.124.121	21407	224.0.124.169	21408
2C	Complex Order	224.0.124.122	22407	224.0.124.170	22408
3C	Complex order	224.0.124.123	23407	224.0.124.171	23408
4C	Complex Order	224.0.124.124	24407	224.0.124.172	24408
5C	Complex Order	224.0.124.125	25407	224.0.124.173	25408
6C	Complex Order	224.0.124.126	26407	224.0.124.174	26408
7C	Complex Order	224.0.124.127	27407	224.0.124.175	27408
8C	Complex Order	224.0.124.128	28407	224.0.124.176	28408
9C	Complex Order	224.0.124.232	29407	224.0.124.236	29408
AC	Complex Order	224.0.124.233	30407	224.0.124.237	30408
BC	Complex Order	224.0.124.234	31407	224.0.124.238	31408
CC	Complex Order	224.0.124.235	32407	224.0.124.239	32408

D.4 DR Retransmission

<u>Feeds</u>	<u>DR Retransmission Server 1</u>	<u>DR Retransmission Server 2</u>	<u>TCP Port</u>
Trading slice 1 (11, 15, 1P, 1C)	198.235.27.239	198.235.27.247	21410
Trading slice 2 (21,25, 2P, 2C)	198.235.27.239	198.235.27.247	22410
Trading slice 3 (31, 35, 3P, 3C)	198.235.27.239	198.235.27.247	23410

Feeds	DR Retransmission Server 1	DR Retransmission Server 2	TCP Port
Trading slice 4 (41, 45, 4P, 4C)	198.235.27.239	198.235.27.247	24410
Trading slice 5 (51, 55, 5P, 5C)	198.235.27.239	198.235.27.247	25410
Trading slice 6 (61, 65, 6P, 6C)	198.235.27.239	198.235.27.247	26410
Trading slice 7 (71, 75, 7P, 7C)	198.235.27.239	198.235.27.247	27410
Trading slice 8 (81, 85, 8P, 8C)	198.235.27.239	198.235.27.247	28410
Trading slice 9 (91, 95, 9P, 9C)	198.235.27.239	198.235.27.247	29410
Trading slice 10 (A1, A5, AP, AC)	198.235.27.239	198.235.27.247	30410
Trading slice 11 (B1, B5, BP, BC)	198.235.27.239	198.235.27.247	31410
Trading slice 12 (C1, C5, CP, CC)	198.235.27.239	198.235.27.247	32410

Appendix E Test HSVF Details

E.1 Test Rendezvous Point (“RP”)

<u>Description</u>	<u>Address</u>
Test environment RP	198.235.30.26

E.2 Test HSVF Multicast Sources

<u>Description</u>	<u>Source IP</u>	<u>Advertised Route</u>
Test ISV 2 feeds	198.235.30.49	198.235.30.49/32

E.3 Test HSVF Multicast Lines

<u>Line</u>	<u>Description</u>	<u>ISV 2 Multicast Groups</u>	<u>UDP Port</u>
11	Top of book	224.0.186.49	11404
21	Top of book	224.0.186.50	12404
15	Market depth	224.0.186.57	11405
25	Market depth	224.0.186.58	12405
1P	PIP only	224.0.186.65	11406
2P	PIP only	224.0.186.66	12406
1C	Complex Order	224.0.186.73	11408
2C	Complex Order	224.0.186.74	12408

E.4 Test Retransmission

<u>Feed</u>	<u>ISV 2 Retransmission Server</u>	<u>ISV 2 TCP Port</u>
Trading slice 1 (11, 15, 1P, 1C)	198.235.30.20	11410
Trading slice 2 (21, 25, 2P, 2C)	198.235.30.20	12410



BOXSM
TECHNOLOGY

